

Technion, Haifa - June 21<sup>st</sup>, 2016

# DPF Inspection & Maintenance Methodology and Practice

Thomas W. Lutz

**Maintenance** must be a periodic routine  
**and**  
**emission control** must become part of  
**maintenance**

→ **Guarantees emission stability**

→ **Preserves the engine in optimum condition**

→ **Reduces overall costs**

(by preventive repair, avoidance of operation interruptions...)

# Technical Requirements

- The vehicles are equipped with **certified filters** ( $\eta > 97\%$ ) and **wireless dataloggers**
- Certified **PN** (plus **CO**) **measurement devices**, portable, low cost and highly sensitive are **available**
- The **obligation** for periodical maintenance of emission relevant components, particle emission checks and documentation is **defined by a mandatory regulation**

## Potential of PN-Measurement

- Fast, handheld, accurate PN-measurement for:
  - Fleet maintenance and control
  - Roadside measurement
  - Official periodic emission checks

allow

- to verify filter efficiency
- to detect small repairable DPF defects
- may indicate the need for filter exchange
- to detect engine malfunctions

# Portable Particle Emission Analyser

Condensation nucleus counter by TSI - NPET

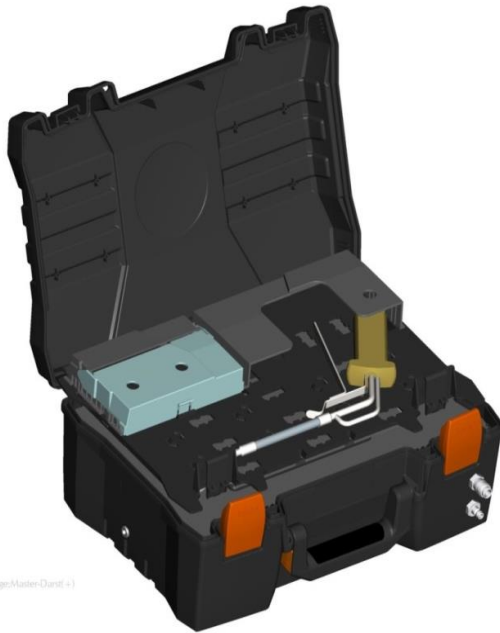

Diffusion charging  
by TESTO - PEPA

# Can small failures be detected by PN at low idle ?

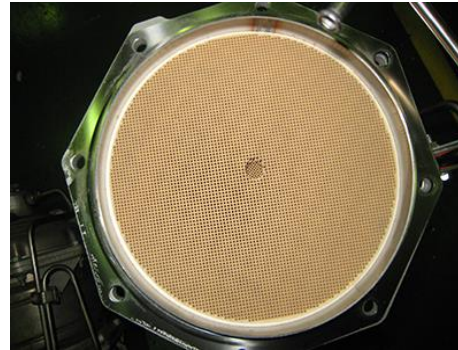

1 hole (0.5%)

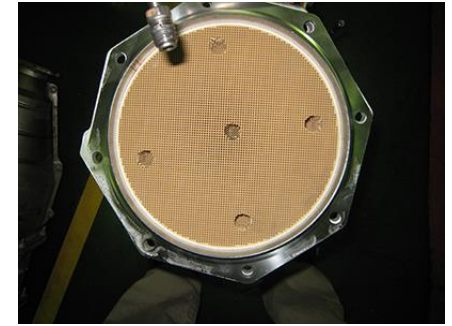

5 holes (2.7%)

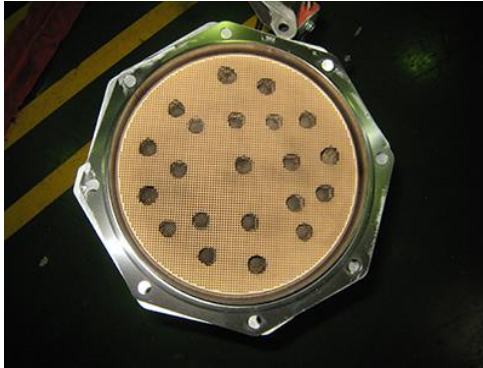

17 holes (9.3%)



41 holes (22.5%)



Completely (100%)

Source: Yamada, ETH-NPC 2015

# PN Increase vs. DPF Damage

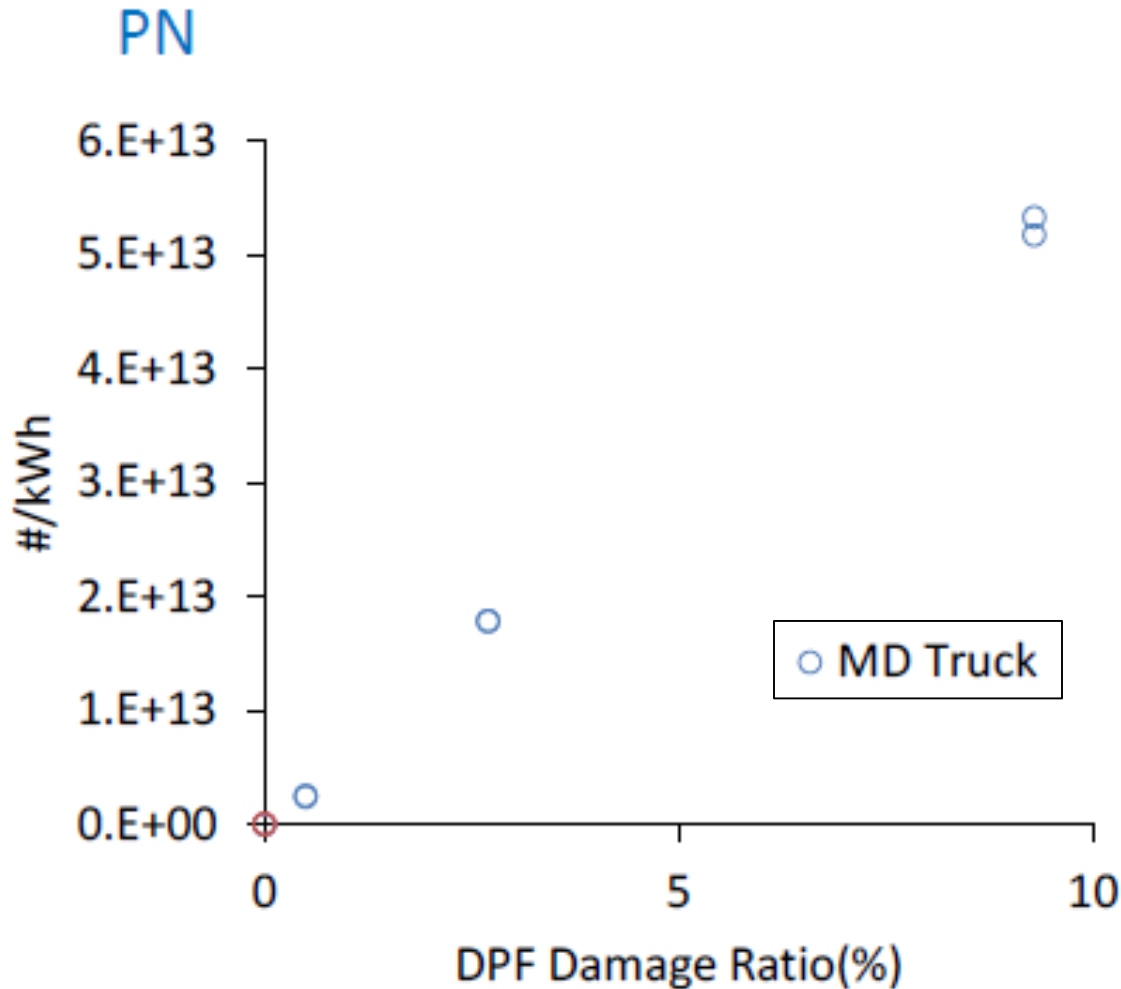

Measured at low idle

Source: Yamada, ETH-NPC 2015

# I&M Organization

## Run by:

### Test-only-stations

- Authorities
- Authorized private organizations

### Test+repair-stations/shops

- Private workshops
- Users/fleet owners

### Supervision on-road/on-sites

Authorities



# General I&M Strategies

## EFFECTIVENESS TEST OF EMISSION CONTROL SYSTEM

## PERIODIC EMISSION CONTROL SYSTEM MAINTENANCE

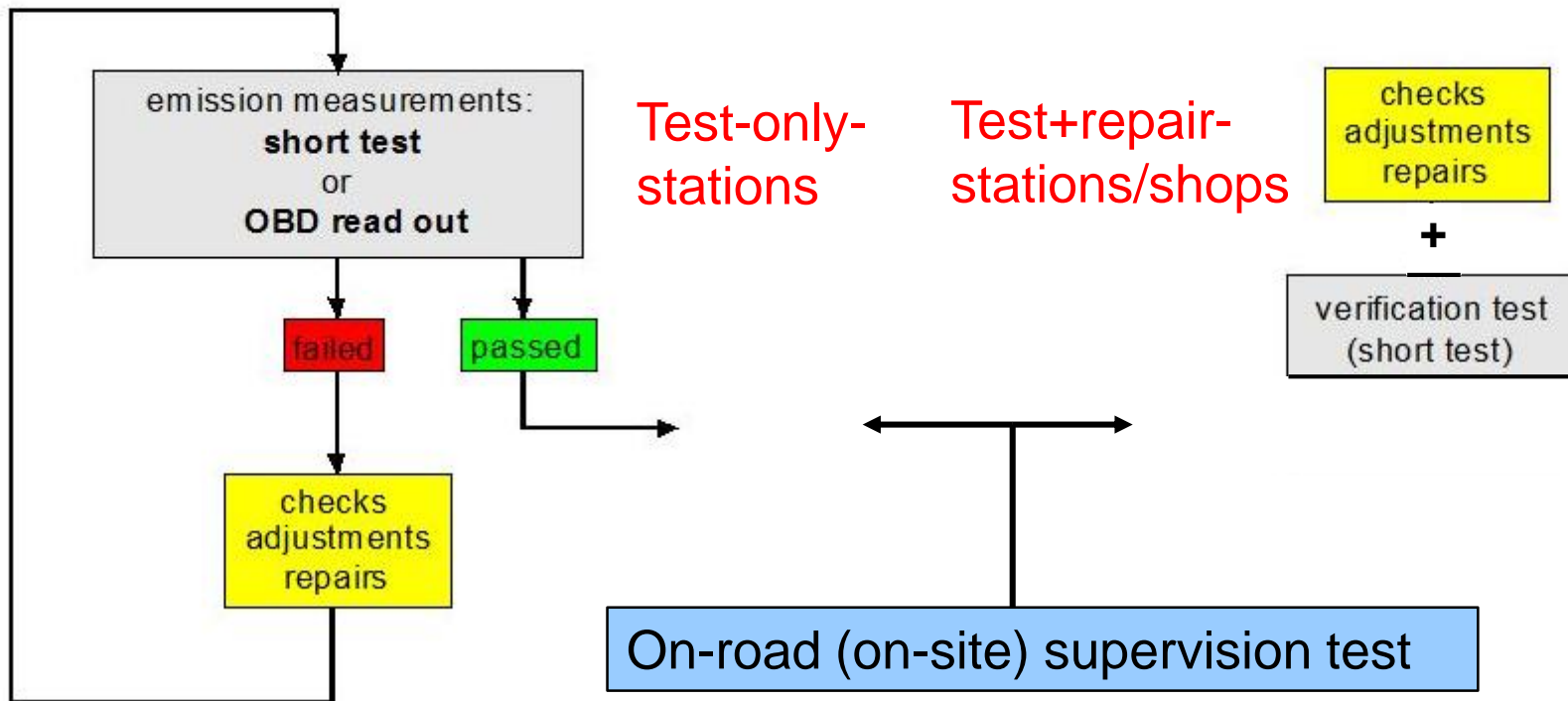

# I&M Concept Elements (1)

(to be defined)

- **Vehicle categories liable to I&M**
- **I&M concept**
- **I&M procedures:**
  - tests
  - minimum maintenance
- **I&M intervalls**
- **Quality criteria for I&M performers:**
  - personnel
  - equipment
- **Certification of I&M performers**

## I&M Concept Elements (2)

- **Costs**
- **Data collection / individual documentation**
- **Quality control of I&M performers:** e.g. test equipment (periodical calibration)
- **Enforcement by on-road tests:**
  - procedure
  - crew training
  - equipment
  - financing
  - fines

**etc.**

# Typical I&M Procedure - Checks

- ① Regular inspection (e.g. busses every 6 month, *authorized institution*)
- ② Periodical maintenance of emission relevant components (*user, workshop*) (e.g. NRMM CH)
- ③ Supervision on-road (on-site) (*authorities*)

# Typical I&M Procedure - Checks

- ① **Regular inspection (e.g. busses every 6 month, *authorized institution*)**
- ② Periodical maintenance of emission relevant components (*user, workshop*) (e.g. NRMM CH)
- ③ Supervision on-road (on-site) (*authorities*)

# Regular Inspection – Inspection Scope

①

- **Identification of the vehicle**
- **Measurement of PN at low idle (end pipe)**
  - PN < 100'000/cc → filter system OK
  - PN > 1'000'000/cc → filter or engine failure
- ▶ The operator of the vehicle is obligated to a regular engine and filter system maintenance procedure and a retest by an authorized institution in case of a PN emission above a given limit

# Typical I&M Procedure - Checks

- ① Regular inspection (every x month, *authorized institution*) (e.g. busses)
- ② **Periodical maintenance of emission relevant components (*user, workshop*) (e.g. NRMM CH)**
- ③ Supervision on-road (on-site) (*authorities*)

# Maintenance of Emission Relevant Components: Procedure

②

- **Visual Checks:** - tightness of all systems
  - oil and soot deposits in the exhaust pipe
  - signs of overheating of the filter housing
- **Maintenance** of engine, filter system and crank case ventilation (in case of a closed version), corresponding to the instructions of the manufacturer
- **Data analysis** (wireless datalogger), e.g.:
  - too high backpressures (when and where on the route)
  - temperatures (e.g. low idle phases)
- **Cleaning of filter if necessary**, → the cleaned filter has to be checked by a PN measurement at low idle (end pipe)



# Maintenance of Emission Relevant Components: Procedure (cont.)

- **Determination of filter efficiency**

- ▶ If the efficiency is below 90% and the PN emission is above the allowed limit:



- **Visual check** of the filter for damages (if less than 10%: → repair, otherwise replacement)
- If a **bad engine condition** is assumed: measurement of PN or opacity before filter at free acceleration and determination of the k-value, ev. oil analysis
- **DOC** (CRT systems): CO conversion measurement: If necessary, cleaning of DOC or replacement
- **Confirmation** in the inspection document

# Determination of Filter Efficiency

The filter masks the engine. Measurement upstream and downstream is needed to get information about engine raw emission and filter efficiency

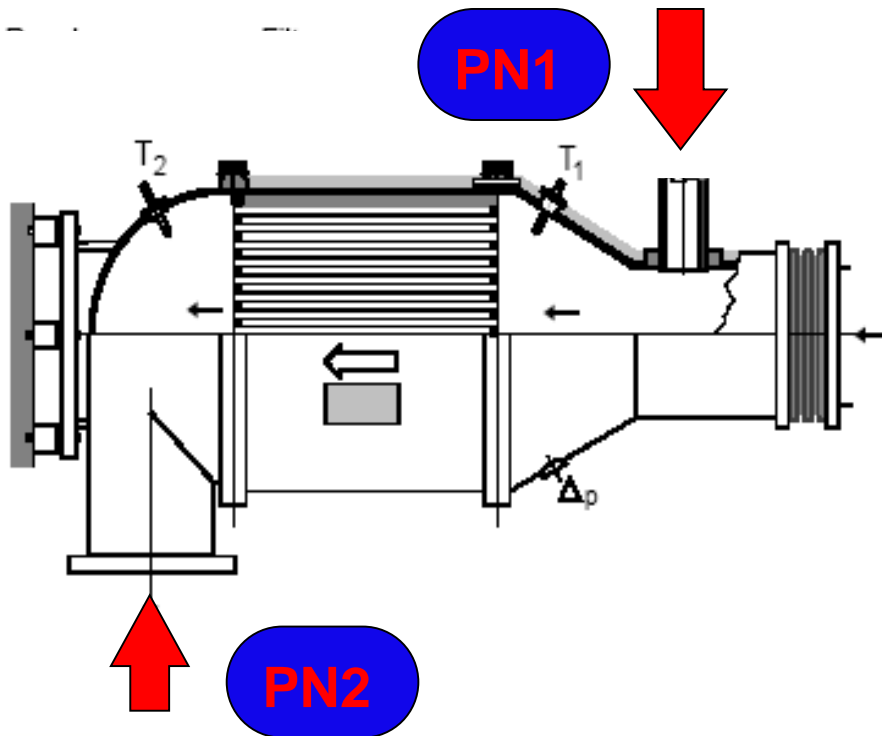

PN1 before the filter determines the emission status of the engine itself, eventual failures, leakages, deterioration, aging

Filtration efficiency:

$$\eta = (PN1 - PN2) / PN1 \cdot 100 [\%]$$

# Repair Small Failures by Ceramic Cement

W.Haldenwanger

Technische Keramik GmbH

Teplitzer Strasse 27

D-84478 Waldkraiburg

**WH Feuerfestkitt Teil A und B**

*[www.haldenwanger.de](http://www.haldenwanger.de)*

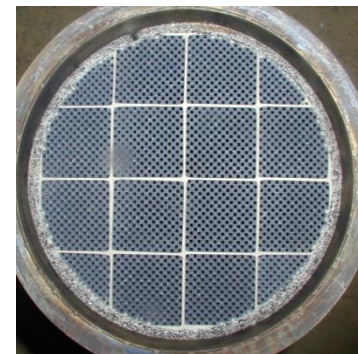

## DOC Light-off Testing

DOC might be covered by soot, poisoned, destroyed, aged or just not adequately coated

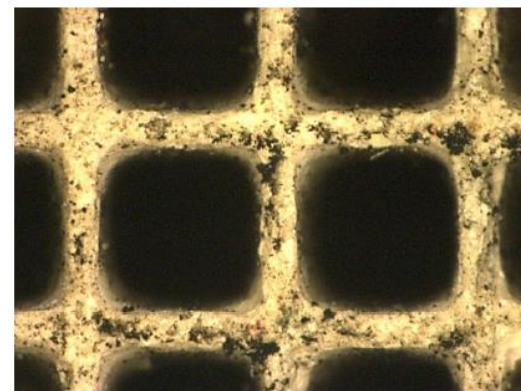
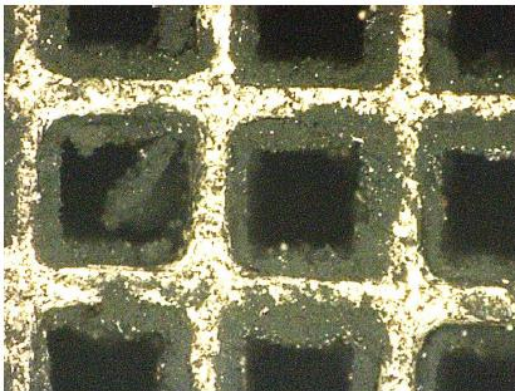

# DOC Light-off Testing

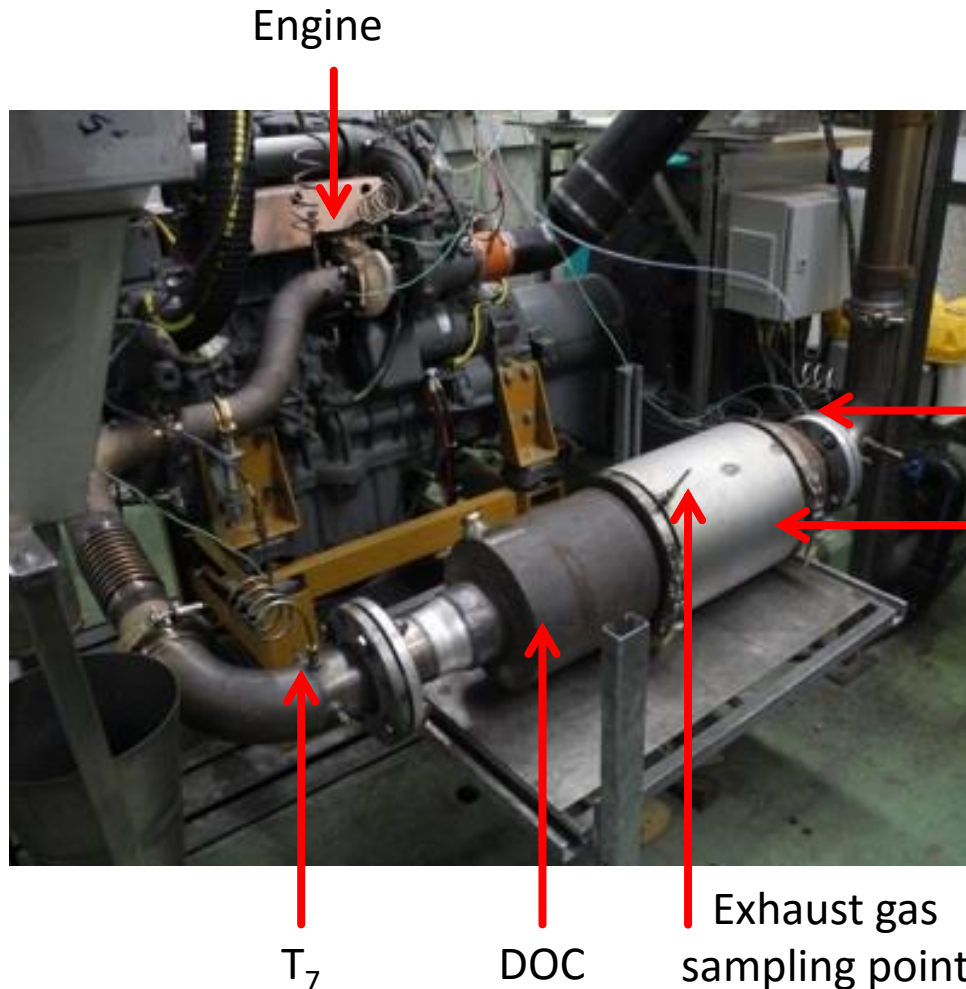

VERT-investigations on a Liebherr D934 Engine, Okt. 2015

**Test facility:**  
 Berne University of Applied Sciences  
 Biel-Bienne, Switzerland  
 IC-Engines and Exhaust Gas Control

Source: BFH

# DOC Light-off Test During Cooling down at Idle

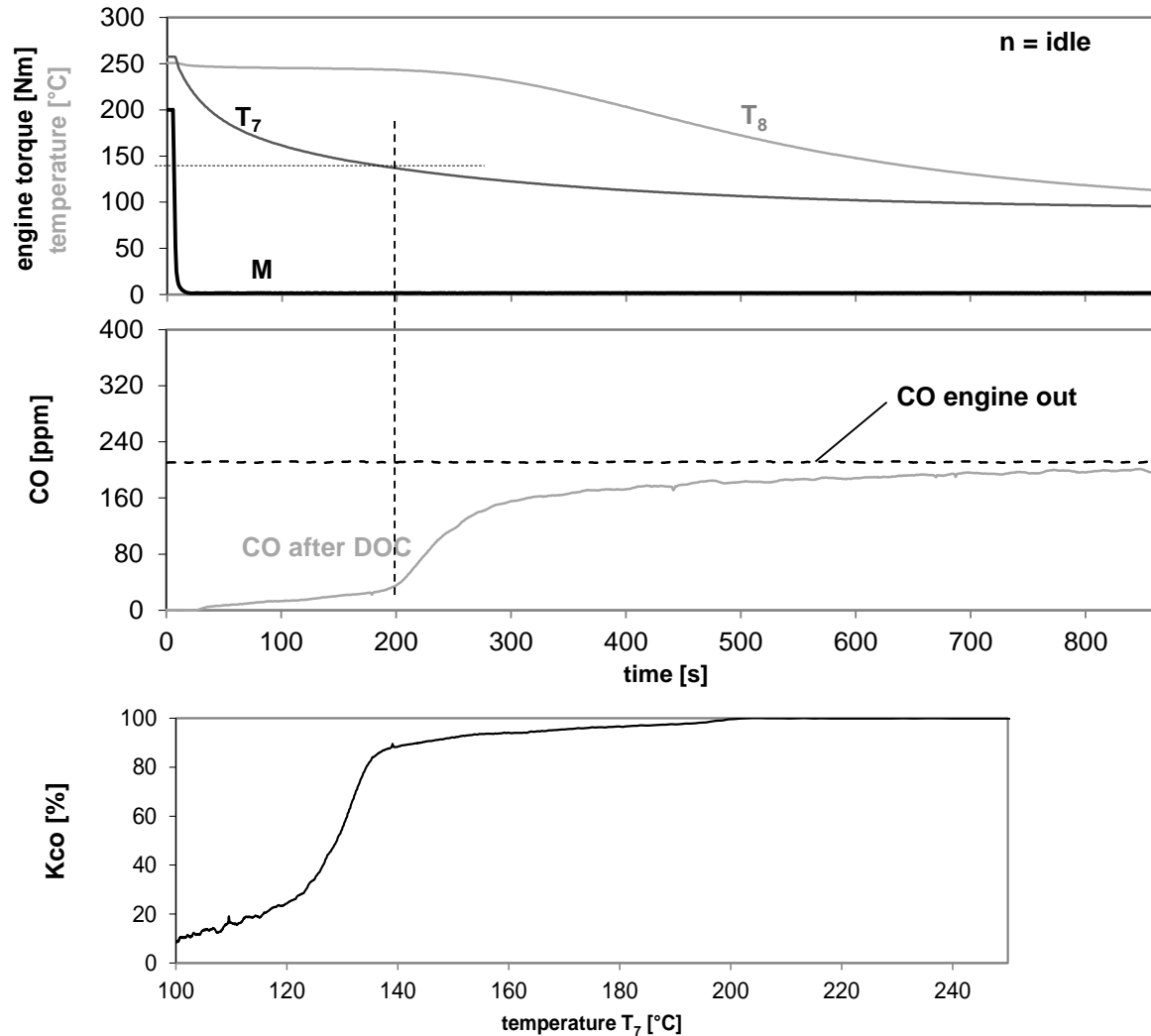

Source: BFH

# Filter Monitoring System (FMS): Elements

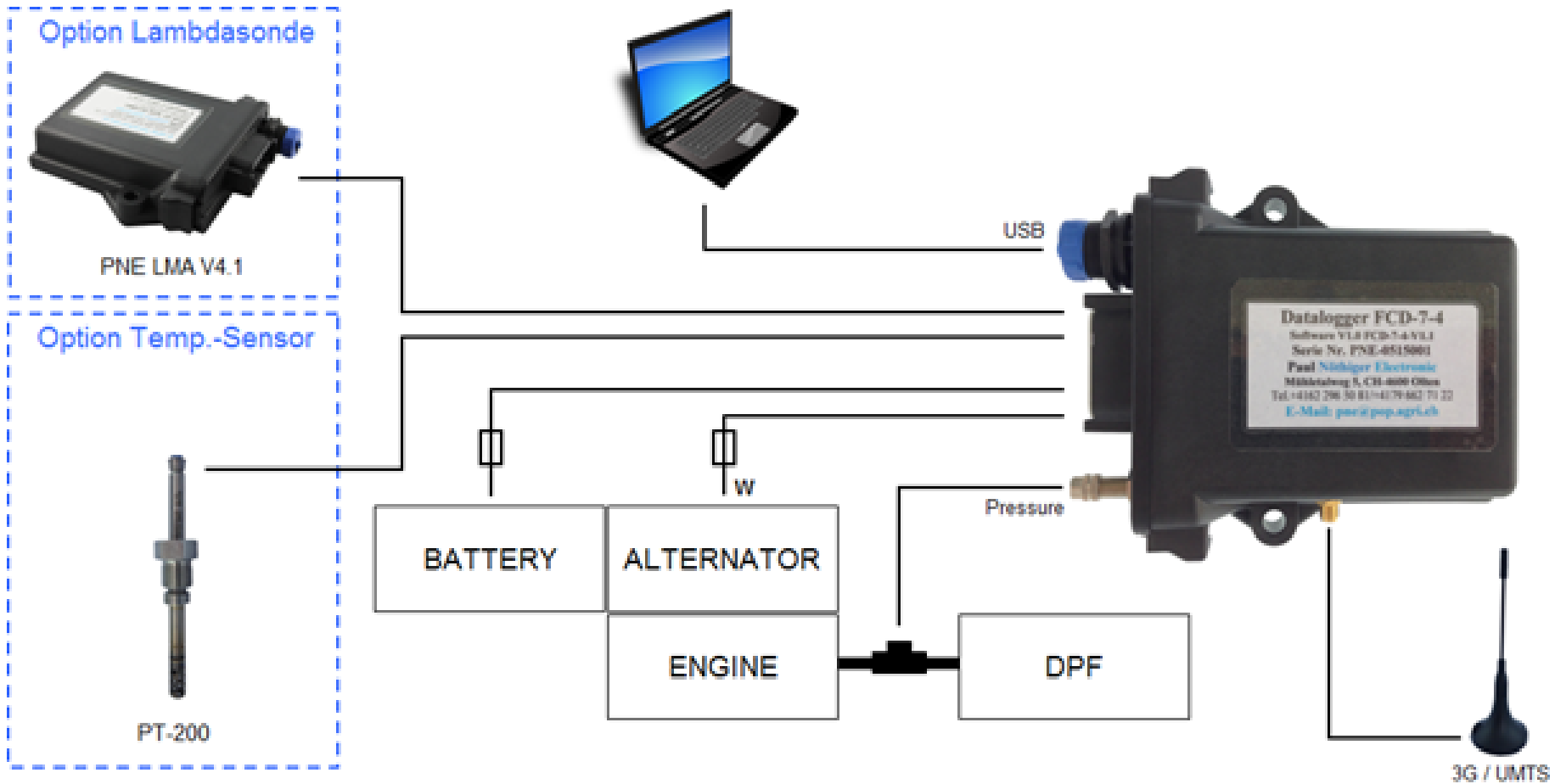

Source: Paul Nöthiger Electronic

# Store Data

- On-board memory
- Server database
- Download data from memory: (**password protected**)
  - local: USB, WLAN, Bluetooth
  - remote: GSM (GPRS)

**GSM** = General System for Mobile Communication

Source: Paul Nöthiger Electronic





# Evaluation

- **Statistics of DPF and vehicle operation**
- **Separation of operating hours and idle time**
- **Real time display and stored data analysis**
- **Trends of temperature and back pressure (normal, unusual)**
- **Comparison of vehicles and filters**
- **Prediction for filter cleaning and other maintenance needs**

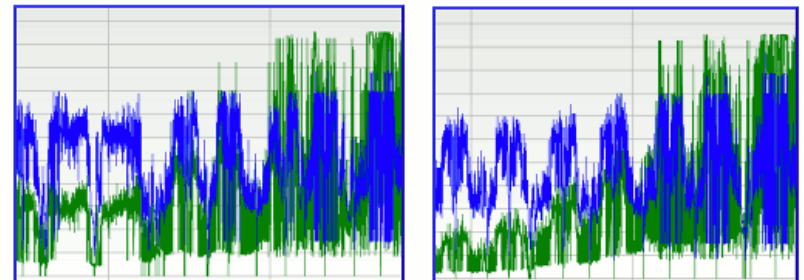

Source: Paul Nöthiger Electronic

# Trend Analysis

Background informations about longterm trends of filter loadingd exhaust gas temperatures, - allows conclusion on normal or unusual operation of filter and engine

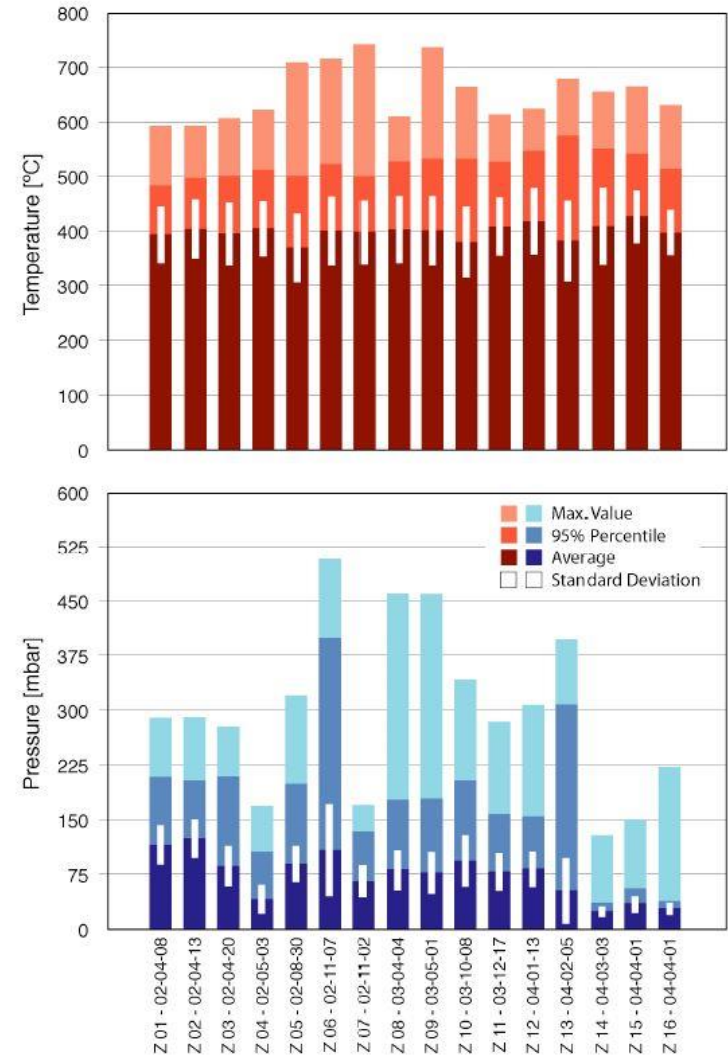

Source: Paul Nöthiger Electronic

# Fleet Overview Report

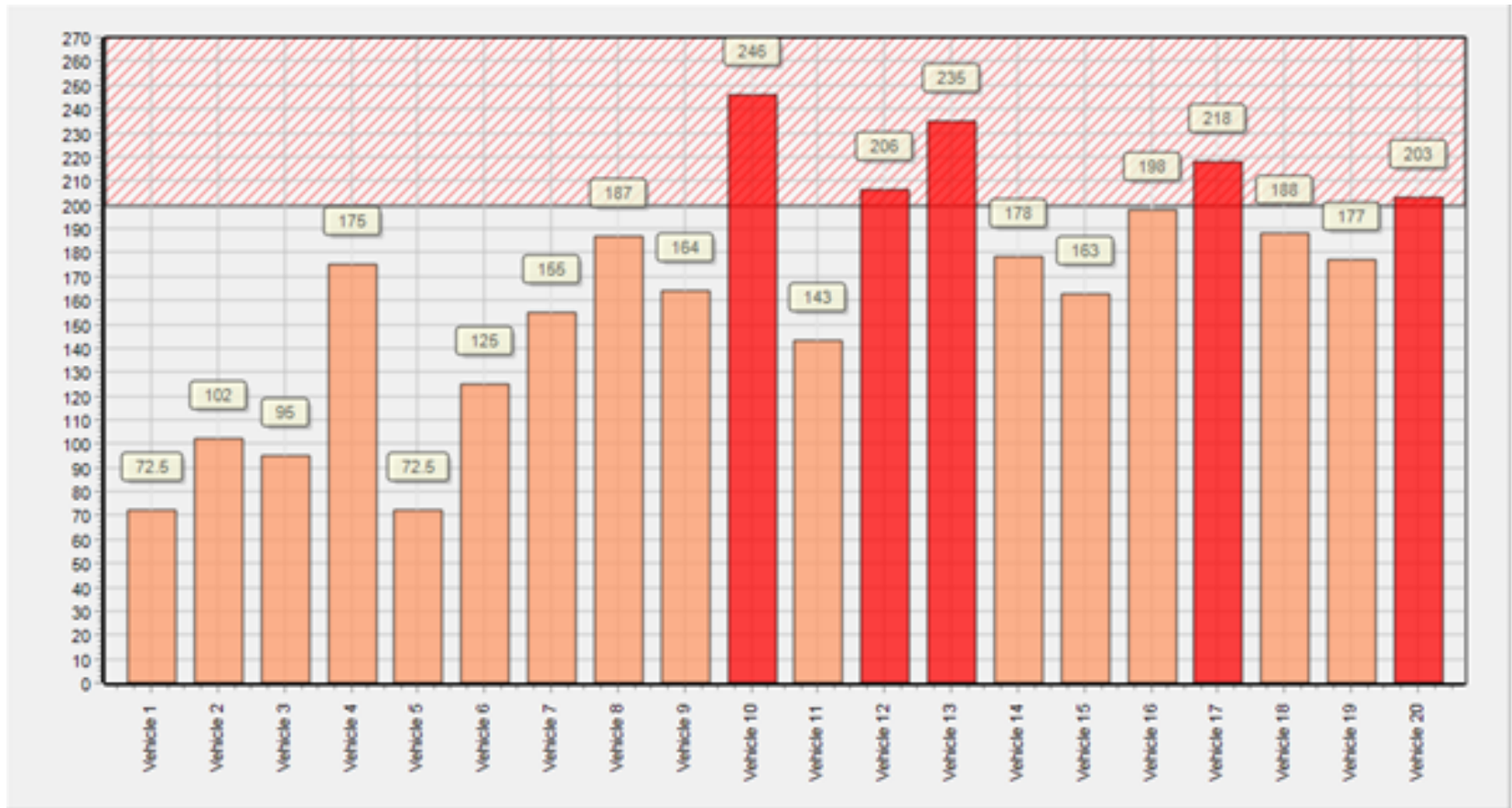

Source: Paul Nöthiger Electronic

**Back pressure – weekly 95%-percentiles**

# Typical I&M Procedure - Checks

- ① Regular inspection (every x month, *authorized institution*) (e.g. busses)
- ② Periodical maintenance of emission relevant components (*user, workshop*) (e.g. NRMM CH)
- ③ **Supervision on-road (on-site) (*authorities*)**

# Supervision Test – On-road / On-site

③

- Identification of the vehicle
- Measurement of PN at **low idle** (end pipe)
- If the limit of (*CH regulation*) **250'000 #/cm<sup>3</sup>** is exceeded:
  - ▶ then the operator of the vehicle is obliged to a regular engine and DPF system maintenance procedure and a retest by an authorized institution



# On-road Check

Santiago de Chile,  
July 2015

Equipment:  
**TSI-NPET**

# Individual Documentation

- Content:**
- Vehicle main data
  - (retrofit date)
  - low and high idle speed
  - (start of fuel delivery)
  - PN before and after filter at low idle
  - rubrics for inspection confirmations

# CH Inspection Document

**ABGAS-WARTUNGSDOKUMENT**

---

**FICHE D'ENTRETIEN  
DU SYSTÈME ANTIPOLLUTION**

---

**DOCUMENTO SULLA MANUTENZIONE  
RELATIVA AI GAS DI SCARICO**

**Diesel**

Muss stets im Fahrzeug mitgeführt werden  
Doit toujours rester dans le véhicule  
Il presente documento deve sempre accompagnare il veicolo



Gesetzliche Vorschriften auf Seite 6 und 7  
Voir prescription légale aux pages 6 et 7  
Prescrizioni legali, vedere pagine 6 e 7

© Herausgegeben vom Verband Schweiz, Baumaschinen-Fabrikanten und Handelstfirmen  
© Editée par l'Association des Fabricants et Négociants suisses de machines pour entrepreneurs  
VSBM-Sekretariat, c/o VSG, Postfach 656, CH-4010 Basel

1

<p>① <b>Fahrzeugdaten / Données du véhicule / Dati del veicolo</b></p> <ul style="list-style-type: none"> <li>• Marke Marque Marca</li> <li>• Fahrzeugtyp Type du véhicule Tipo veicolo</li> <li>• Fahrgestell-Nr. No du châssis Telaio no</li> <li>• Motor-Kennzeichen Identification du moteur Identificazione motore</li> </ul>
<p>② <b>Messbedingungen / Conditions de mesure / Condizioni di misurazione</b></p> <ul style="list-style-type: none"> <li>• Motor auf Betriebstemperatur bringen. - Alle elektrischen Verbraucher ausschalten. - Erfolgt die Messung in grösseren Höhen als 600 m ü. M., so sind bei Fahrzeugen ohne Druckkorrektur zur Berücksichtigung des Höhenflusses vom gemessenen Wert, je 0,25 m<sup>-1</sup> bzw. 0,5 Bacharach pro 400 m grössere Höhe abzuziehen. Es ist der korrigierte Wert einzutragen. - Weitere Angaben des Herstellers beachten.</li> <li>• Chauffer le moteur à sa température de marche. - Déclencher tous les consommateurs électriques. - Pour tenir compte de l'influence de l'altitude sur les véhicules sans correction de pression, lorsque des mesures sont effectuées à des altitudes excédant 600 m, on déduira respectivement 0,25 m<sup>-1</sup> ou 0,5 indice de croissance Bacharach par tranche de 400 m au-dessus. - Il y a lieu d'inscrire la valeur corrigée sur la fiche d'entretien. - Consulter attentivement les indications du constructeur.</li> <li>• Portare il motore a temperatura di marcia. - Staccare tutti i consumatori di elettricità. - Per poter tener conto dell'influenza barometrica esercitata sui veicoli senza correttore di pressione, nel caso di misurazioni effettuate ad altitudini superiori a m. 600, si dedurrà ripetutamente 0,25 m<sup>-1</sup> o 0,5 indice di opacizzazione Bacharach per fasce supplementari di 400 m. - Solo il valore corretto viene registrato sul foglio di manutenzione. - Attenersi alle indicazioni del costruttore.</li> </ul>

2

<b>Sollwerte des Herstellers</b>	<b>Valeurs du constructeur</b>	<b>Dati del costruttore</b>
③ <b>Kontrollwerte / Indications de réglage / Indicazioni di regolazione</b>		
• Leerlaufdrehzahl Régime de ralenti Regime del minimo		min <sup>-1</sup>
• Obere Leerlaufdrehzahl Régime maximal à vide Regime massimo, a vuoto		min <sup>-1</sup>
• Förderbeginn Commencement du débit Inizio mandata	- statisch statique statica  - dynamisch dynamique dinamica	mm <sup>2</sup>  l/min <sup>-1</sup>
• Plomben und/oder Verweigungen Pombs et/ou souaux Pombi e/o sigili		
④ <b>Rauchemissionswerte / Valeurs des émissions de fumées / Valori delle emissioni di fumo</b>		
• Trübungskoeffizient Coefficient d'opacité coefficiente d'opacità	maximal maximum massimo	m <sup>-1</sup>
• Schwirgungszahl Degré de noircissement grado di annerimento	maximal maximum massimo	Bacharach
⑤ <b>Bestätigung / Attestation / Attestazione</b>		
		Datum, Sign.
<ul style="list-style-type: none"> <li>• Der Interzechierte bestätigt, dass die Abgaswartung nach Herstellerschrift und unter Verwendung der vorgeschriebenen Messgeräte ausgeführt wurde.</li> <li>• Le soussigné atteste que le service d'entretien du système antipollution a été exécuté conformément aux indications du constructeur et en utilisant les appareils de mesure prescrits.</li> <li>• Il firmatario attesta che il servizio di manutenzione del sistema anti-inquinamento è stato eseguito conformemente alle indicazioni del costruttore e utilizzando gli apparecchi di misura prescritti.</li> </ul>		Stempel / Timbre / Timbro



# Conclusions

## The instruments are ready:

- PN-measurements at low idle for DPF and engine control
- Filter monitoring with remote control (datalogging)
- DOC-conversion activity control is in the test phase (CRT systems)

## For the implementation of a consistent I&M strategy

- **Regulations are needed**
- **Periodic independent checks are needed**
- **A documentation is needed (emission document on-board)**

**Inspecting vehicles does not  
reduce pollution,  
MAINTAINING / REPAIRING  
them does**

Cliff Grove, Automotive Diagnostics,  
SPX Corporation, USA 1996